

BENDING AND MACHINING

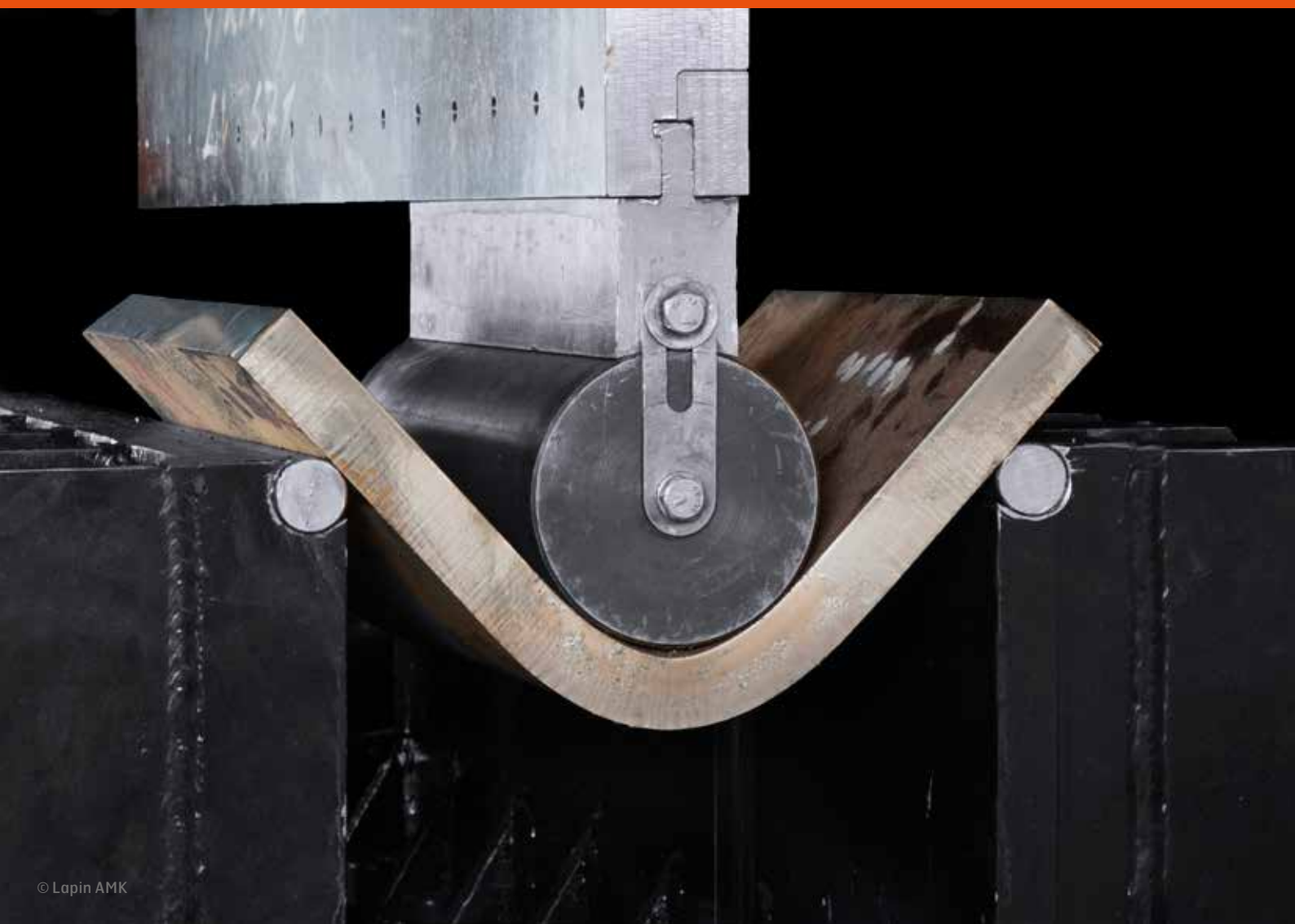

ABRASION RESISTANT STEEL FOR DEMANDING PRODUCTS

Raex abrasion-resistant steel is designed to withstand demanding conditions, where steel structures are exposed to a high level of abrasive wear and tear. The wear resistance properties of Raex can significantly prolong the service life of your equipment and reduce the expenses in time and money.

Raex extends the service life of steel structures by cutting down their weight in comparison to mild steel. Lighter components increase load capacity, often 10 – 20 percent and sometimes even more. This saves fuel and reduces emissions by reducing the number of trucks in service.

INTRODUCTION

Raex is an abrasion-resistant steel with excellent hardness, good impact toughness and ultra high strength. Raex steels are delivered as cut to length sheets and heavy plates. Raex helps extend the lifespan of machinery, decrease wear in structural components and save costs. It enables innovative design and lightweight products that improve energy efficiency.

The brochure describes the principles of free bending and bottoming and gives practical recommendations for bending of Raex. Generally, the need for bend force and the level of springback increase as the strength of steel increases. To obtain full advantage of good bendability of Raex, careful workshop practices must be in place.

Worn tools, poor lubrication, damaged surface, burrs on cut edges, may all impair bending quality. Plates taken from a cold storage must be allowed to warm up to room temperature before being cold formed.

In addition to bend instructions, the brochure compiles information and recommendations on machining of Raex, including the following methods:

- drilling
- thread cutting
- sawing
- milling and turning.



BENDING METHODS

The plate is bent to the designed angle or free bending radius in a flanging press between the punch and the die.

In free bending, the plate rests on the upper edges of the die gap for the entire duration of the pass. The required bending radius is obtained by adjusting the stroke length (Figure 1). The die gap width can be adjusted.

In bottoming, the stroke length is sufficient for the punch to press the plate entirely against the die. An edge matching that of the punch and die is formed in the plate (Figure 1). The die gap (V-groove) is fixed and its width cannot be adjusted.

PREPARATION BEFORE BENDING

- The temperature of the plate must be a minimum of +20°C.
- It is recommended to bring plates stored in cold places indoors a day prior to bending operations.
- If required, the area to be bent must be heated using a gas flame.
- Preheating to +100 – +200°C reduces the required bending force and improves bendability in general.
- Identify the rolling direction of the plate.
- Possible surface defects must be grind away from the tension side face of the plate.
- Grind away defects on the cut edge of a thermally or mechanically cut plate, at least on the area to be bent.

FIGURE 1. BENDING METHODS AND TOOLS.

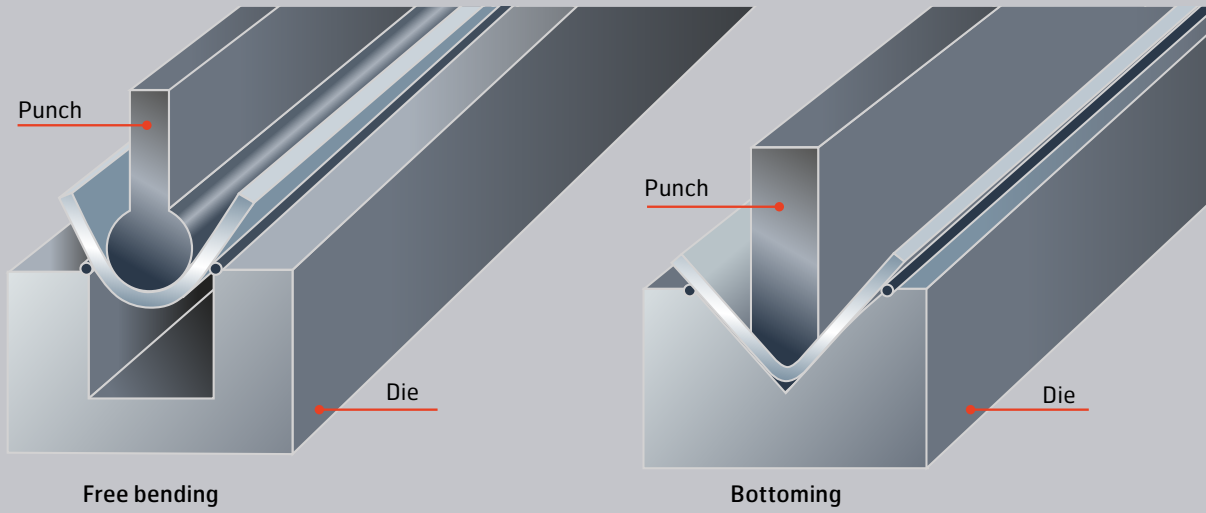
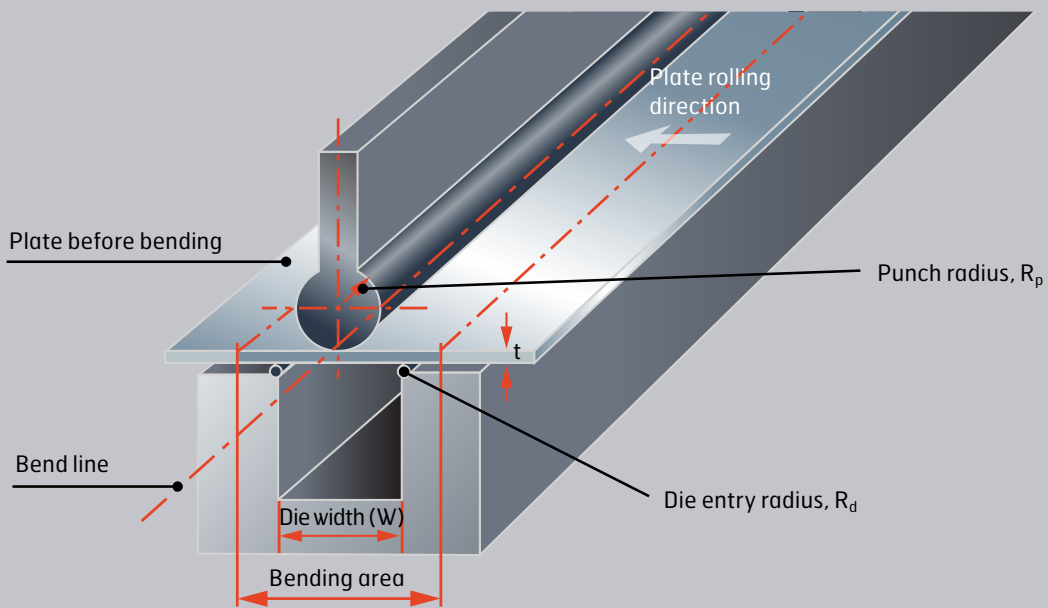

FIGURE 2. BENDING TRANSVERSE TO THE ROLLING DIRECTION IS RECOMMENDED.





BENDING INSTRUCTIONS

- Safety instructions must be followed in bending.
- The need for bending force, springback effect and the permitted bending radius increase as the strength of the steel increases.
- The widest possible bending radius must be used.
- Flanging must be made in a single pass.
- The best possible workshop expertise can be obtained by combining theoretical and empirical data.
- Bending values are defined on the basis of test bending taking the degree of the springback effect into consideration.
- Springback effect in Raex 400 is 8° – 25° and Raex 500 15° – 35°, depending on bending tool parameters. Wider die-gap results in bigger springback.
- Trial tests are always recommended.

BENDING INSTRUCTIONS FOR THE WORKSHOP

In practical bending or flanging, the punch diameter is defined on the basis of steel grade, plate thickness and bend radius. Table 1 presents the punch diameter (D), plate thickness (t) and internal bend radius (R) for Raex 400, Raex 450 and Raex 500.

BENDING FORCE

The bending force (P, in metric tons) needed when bending of steel plates can be estimated using the following formula:

$$P = \frac{b \cdot t^2 \cdot R_m}{(W - R_d - R_p) \cdot 9800}$$

- P = Bend force, metric tons
- t = Plate thickness, mm
- W = Die width, mm (figure 2)
- b = Bend length, mm
- R_m = Tensile strength, MPa (table 2)
- R_d = Die entry radius, mm (figure 2)
- R_p = Punch radius, mm

TABLE 1. RAEX ABRASION-RESISTANT STEELS. BENDING INSTRUCTIONS FOR THE WORKSHOP.
Selection of the minimum allowed punch diameter for Raex on the basis of plate thickness and bending radius

Punch diameter D (mm)	Bending radius R (mm)	RAEX 400		RAEX 450		RAEX 500	
		Plate thickness t (mm) to be trans- versely ¹⁾ bent	Plate thickness t (mm) to be longitud- inally ¹⁾ bent	Plate thickness t (mm) to be trans- versely ¹⁾ bent	Plate thickness t (mm) to be longitud- inally ¹⁾ bent	Plate thickness t (mm) to be trans- versely ¹⁾ bent	Plate thickness t (mm) to be longitud- inally ¹⁾ bent
12	6	2					
16	8		2				
18	9	3					
24	12	4	3	3			
30	15	5			3	3	
36	18	6	4	4			3
40	20		5	5	4	4	
50	25	8	6	6			4
56	28	9	7	7	5	5	
60	30	10					5
72	36	12	8	8	7	7	6
80	40	13	10	10			
100	50	16	12	12		10	8
110	55	18			10		
120	60	20	15	15			10
140	70				14	14	
170	85		20	20			14
200	100				20	20	
240	120						20

¹⁾ Bending line vs. plate rolling direction.

When bending in V groove (90°) the recommended die width and plate thickness ratio is $W/t = 15$.

Typical tensile strength of Raex steels is presented in table 2.

TABLE 2. RAEX ABRASION-RESISTANT STEELS. TYPICAL TENSILE STRENGTH AND HARDNESS VALUES.

Raex grade	Tensile strength R_m (MPa)	Hardness (HBW)
Raex 300	1000	300
Raex 400	1250	400
Raex 450	1450	450
Raex 500	1600	500



MINIMUM BEND RADIUS

Table 3 shows the minimum bending radii for Raex abrasion-resistant steels. In practical bending or flanging in the engineering works, it is recommendable to use inside bending radii which are greater than the minimum allowed bending radii. In addition to the steel plate, the quality of the bend depends on the bending tools and the performance of the work. Successful bending requires good engineering workshop technology from the steel product processor. Worn-out tools, insufficient lubrication, scratches on the steel surface and burr compromise the quality of the cold forming process.

TABLE 3. RAEX ABRASION-RESISTANT STEELS. MINIMUM BEND RADIUS R, BEND ANGLE $\leq 90^\circ$.

Raex grade	Product form	Thickness (mm)	R/t minimum transverse	R/t minimum longitudinal	Die opening width W/t minimum
Raex 300	Sheet	2 – 8	3	3	12
Raex 400	Sheet	2 – 8	3	4	12
	Plate	6 – 20	3	4	14
Raex 450	Sheet	2.5 – 8	3	4	12
	Plate	6 – 20	4	5	14
Raex 500	Sheet	3 – 6.5	3.5	4	14
	Plate	6 – 20	5	6	14

SEPARATION OF THE PLATE TO BE BENT

Figure 3 shows the separation (A) of the plate to be bent from the circle of the punch diameter (D). The separation is well-known for the engineering works that are using high strength steels. Generally, the accuracy of the final bend angle is more important than the radius of the punch work piece. If the exact bend radius is desired, too, trial bending has to be carried out. As a result of the trial bending, a punch radius is selected that produces a final bend angle matching the target value. In practice, the punch radius is a little bit larger than the directive bending radius of the steel.

FIGURE 3. SEPARATION OF THE PLATE TO BE BENT.

A = Separation of the plate
D = Punch diameter

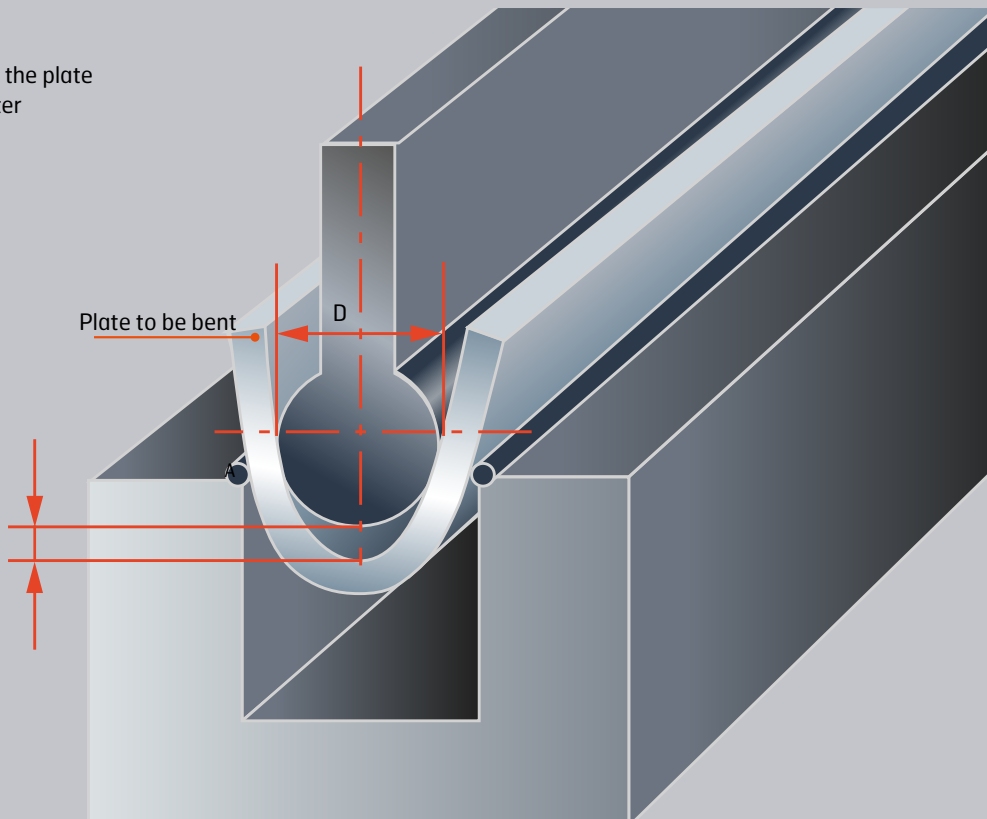

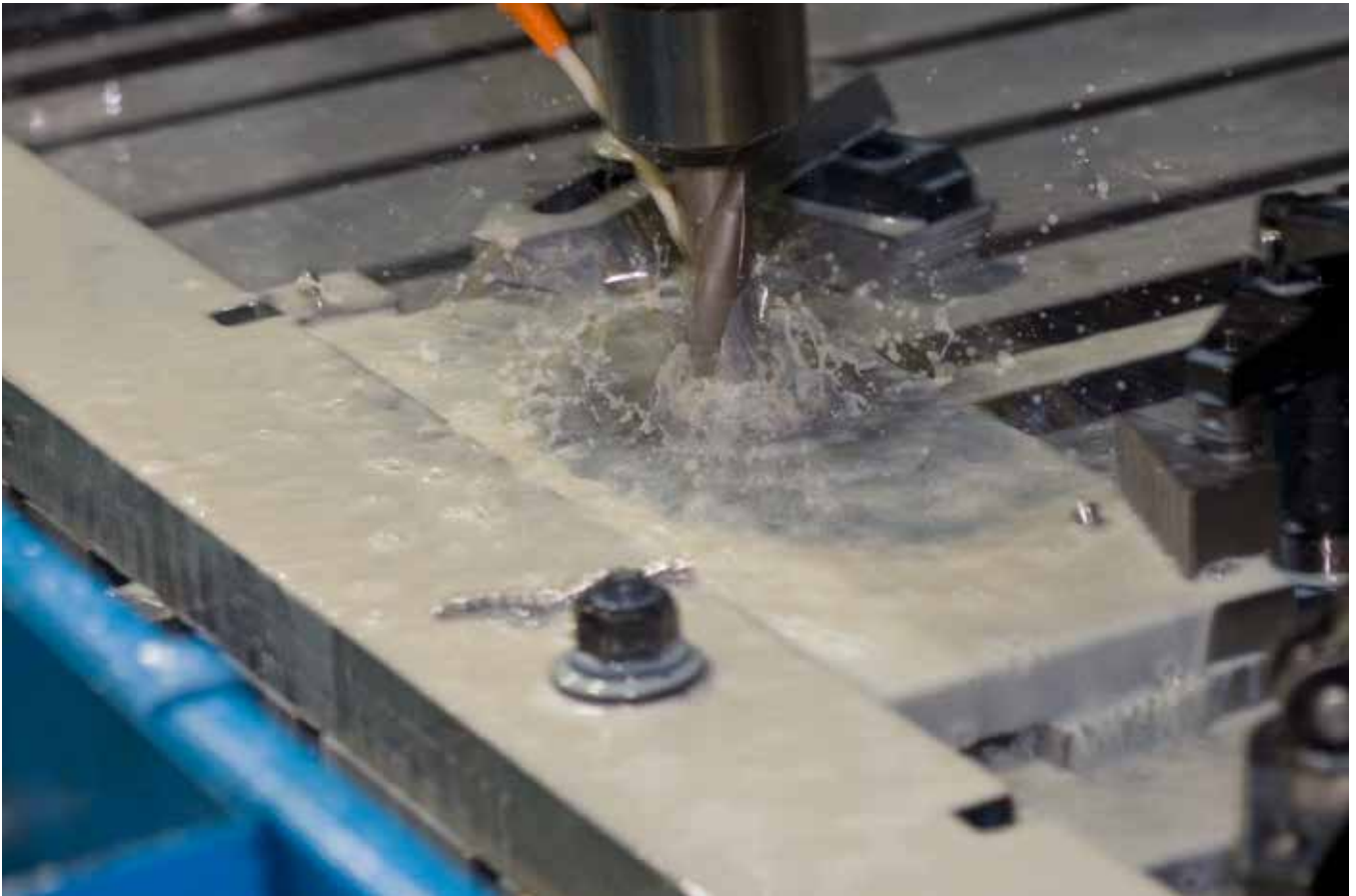

MACHINABILITY

GENERAL INSTRUCTIONS FOR MACHINING:

- The machine must be rigid and stable.
- Clamp the workpiece as rigidly and close to the area to be cut as possible.
- Long tool holders and spindle overhangs must be avoided.
- No harmful vibration may occur during any stage of machining.
- Particular caution must be exercised when starting a cutting operation.
- Grind away any rough edges on a thermally cut plate in the area where the first cut is started.
- Sufficient feed and depth of cut must be used.
- Provide a generous flow of cutting fluid.
- Lower the cutting speed in dry cutting.
- When machining abrasion-resistant steels on a regular basis, hard metal tools should be selected using the manufacturers' data sheets.

DRILLING

Recommended drilling parameters for non-alloyed high-speed steel (HSS) drills and cobalt-alloyed HSS drills are presented in tables 4, 5 and 6. Additionally, recommended drilling parameters for the steel grade Raex 500 using solid cemented carbide drills are included in table 6. Raex 400 and Raex 450 can be drilled with HSS drills. For drilling of Raex 500 hard metal drills are recommended.

GENERAL INSTRUCTIONS FOR DRILLING:

- The drilling machine has to be rigid and stable in order to minimize vibrations.
- Clamp the workpiece securely and close to the area to be machined.
- Short-hole drills are recommended.
- The service life of the drilling tool can be prolonged by decreasing the feed.
- Provide an abundant supply of cutting fluid.

TABLE 4. RAEX 400. RECOMMENDED DRILLING PARAMETERS.

	Drill diameter (mm)	Feed rate (mm/rev)	Feed rate (mm/minute)	Cutting speed (m/minute)	Speed of rotation (rpm)
Uncoated HSS drill	5	0.10	60–80	9–12	600–800
	15	0.20	40–50	9–12	200–250
	25	0.25	30–40	9–12	110–150
Uncoated HSS-Co drill	5	0.10	70–100	12–15	800–950
	15	0.20	50–70	12–15	250–320
	25	0.20	25–30	9–12	110–150

TABLE 5. RAEX 450. RECOMMENDED DRILLING PARAMETERS.

	Drill diameter (mm)	Feed rate (mm/rev)	Feed rate (mm/minute)	Cutting speed (m/minute)	Speed of rotation (rpm)
Uncoated HSS drill	5	0.08	40–50	8–10	500–650
	15	0.20	35–45	8–10	170–210
	25	0.25	25–35	8–10	100–130
Uncoated HSS-Co drill	5	0.10	60–75	8–10	600–750
	15	0.20	35–45	8–10	170–210
	25	0.20	15–20	6–8	75–100

TABLE 6. RAEX 500. RECOMMENDED DRILLING PARAMETERS.

	Drill diameter (mm)	Feed rate (mm/rev)	Feed rate (mm/minute)	Cutting speed (m/minute)	Speed of rotation (rpm)
Uncoated HSS drill	5	0.10	25	4	250
	15	0.15	15	4	85
	25	0.15	8	4	50
Uncoated HSS-Co drill	5	0.10	25–35	4–6	250–380
	15	0.15	15–20	4–6	80–130
Solid cemented carbide drill	16	0.15	120	40	800



MACHINE TAPPING

For thread cutting, micro-alloyed HSS-E or cobalt-alloyed HSS-Co taps with four cutting edges are recommended. The best result is obtained by using cutting oil or paste. When the strength of the joint is not critical, thread holes approximately 3–5 percent larger than the standard values are recommended. A larger hole diameter will significantly increase tool life. During the threading pass, unobstructed chip removal must be secured without reversing the tool or alternating the direction of rotation. Shallow holes should be threaded using appropriate taps, table 7.

TABLE 7. RAEX. MACHINE TAPPING, HSS-E TAP.

	Cutting speed (m/min)	Tap size					
		M10 Spindle speed (rpm)	M16 Spindle speed (rpm)	M20 Spindle speed (rpm)	M24 Spindle speed (rpm)	M30 Spindle speed (rpm)	M42 Spindle speed (rpm)
Raex 400	3.6	115	80	63	53	42	30
Raex 500	1.6	50	40	32	25	21	15

SAWING

When selecting the sawing machine and blade, the high hardness and strength of the steels should be taken into account. A generous flow of cutting fluid should be provided. In band sawing, the best results are achieved with an asymmetric tooth pitch, table 8.

GENERAL INSTRUCTION FOR BAND SAWING:

- The blade must be supported and tensioned adequately.
- The burr and hardened layer caused by flame cutting should be ground away from the area where sawing is started.
- Long chip removal distances should be avoided, for example by clamping the workpiece rigidly in a slanting position.
- If the cutting length cannot be reduced, a blade with a coarser tooth pitch can be used.
- The tooth pressures should be reasonably high.
- Blade noise can be eliminated by adjusting the cutting speed.
- Sawing should always be started using manual feed, and the feed should be adjusted to bring the blade into sufficiently stable contact.
- The hardness and strength of the workpiece should be taken into account when adjusting the feed.
- A generous flow of cutting fluid ensures that the blade remains wet throughout the run.
- Tooth damage is in part caused during the exit phase, when the blade wedges, jams, bites and jitters.

TABLE 8. RAEX. CUTTING DATA FOR SAWING.

	Cutting speed m/min Cutting length mm		
	100	200	300
Raex 400	60	50	40
Raex 500	40	35	30

MILLING AND TURNING

The most common milling operation in the abrasion-resistant steels is roughing. The milling machine must be rigid and of heavy construction. It is necessary to use coated hard metal tools. In terms of cutting data, turning is in principle similar to milling, table 9.

GENERAL INSTRUCTIONS FOR MILLING:

- A generous flow of cutting fluid should be provided.
- Start milling operations carefully.
- The burr and hardened layer caused by flame cutting should be ground away from the area where the milling is started.
- When rough milling, the first cut should be thick enough to keep the cutting edge from dragging on the scaly, hardened surface of the workpiece.

TABLE 9. RAEX. CUTTING DATA FOR ROUGH MILLING.

Wet rough milling	Indexable insert P40		
	Cutting speed (m/min)	Feed (mm/tooth)	Depth of cut (mm)
Raex 400	75–90	0.1–0.2	2–5
Raex 500	60–75	0.1–0.15	1–4

Optimal conditions allow using up to 50% higher cutting data.

For dry milling, 20–30% lower values are recommended.



OCCUPATIONAL SAFETY

Special care has to be taken in processing and handling of ultra high strength steels. If bend radius, for example, is too small and a crack is created in bending point, the plate may fly from the bending tool in the direction of the bend. Those bending the plate must take appropriate precautions to protect themselves and no outsiders are allowed in the area.

The safest location is usually by the bending machine. The handling instructions of the steel supplier and safety instructions of the workshop must be adhered to in detail. New employees must receive appropriate training before they are allowed to process with ultra high strength steels.

CONTACT